



CAST IRON AIR BRICK COMPANY

Building Architectural Enhancements

riba
product
selector

Specification Sheet – ciabCON3-2021

www.castironairbricks.co.uk

73mm CONSERVATION VENT

ITEM NoS... CON3



Cast iron conservation vents are made from grey iron, cast in sand moulds bonded with resin to a fine cast finish and are available in various sizes.

The CON3 is the smallest conservation we have and has a flat back without a protruding spigot with a hole at the back of 73mm diameter . It is therefore suitable for covering a vent or air extraction hole that is 73mm or smaller.

Problem Solver

The CON3 is the latest step forward in the development of the cast iron cowled conservation vent and our smallest vent. Unlike the 4,5 and 6 inch conservation vents, the little 3" vent doesn't have a spigot at the back so can cover any small hole or core drilling. The largest hole it would cover is 3" (75mm) but can go down to cover a weep hole or a simple 10mm drilled hole .

Below is a brief introduction and history of the development of the conservation vents ...

Period properties have period vents and when these require replacement it's easy to replace like for like with a brand new reproduction like one of our Y pattern cast iron air bricks or one of the grid patterns.

The aim of ventilation at the turn of the century was to allow the wind to do all the work and have air flow naturally through a building to prevent damp and mould and allow for room ventilation. In the 21st century, these period properties have evolved and instead of having Victorians and Edwardians living in them they've now got 21st century folk living in them and working in them. Instead of a dairy, wash houses, outside toilet and wash basins they've now got ensuite shower and wc, a main bathroom, a cloakroom, a tumble dryer and hob extractors. Instead of allowing air to flow naturally into the house we extract the air out of the house, mechanically, using electric motors and these terminate on the outside walls of the property and create a problem.

The problem being of course is that all the original vents look original and all the 21st century vents look , well ...21st century. That's not a good look and we know what a pain it was for architects, interior designers, kitchen installers and conservation officers because way back in 2010 they told us. We would receive so many emails with images of plastic terracotta Screwfix cowls bolted onto the side of listed buildings installed in the 80s and repaired with silicon sealant that we felt we had to do something. You said you wanted a cowl because the motors don't want to fight when it's windy to extract the air and you didn't want your clients hearing a flap in the ductwork everytime the extractor came on or there was a breeze. It was a cowl that was needed but it needed to look as if it was original to the house, the sort of grille that the Victorians would have had if they'd invented the tumble dryer. A grille that looked a little like an upside down rain hopper perhaps? So we set to work and created our very first cast iron grille pattern in wood and commissioned a micro foundry in Bristol to cast four so we could show them at the homeshow at the NEC in Birmingham. The feedback was amazing and sure enough a few months later we started to see the conservation vent appearing on tenders and in plans for renovations and conversions and we now sell around 1000 a year, it's our biggest seller.

Construction

The conservation vent is made from fine cast grey iron. The cowl deflects the extracted air downwards and is screwed into the wall through the 5mm diameter countersunk screw holes in the lugs on each corner . There is no spigot at the back, it is flat.

Because it is flat at the back it is easy enough to insert a piece of mesh to stop the ingress of flies. Please note there will be a reduction of 1/3 to the free area available for ventilation and the mesh will require regular cleaning to ensure the free area doesn't drop further due to dirt and dust.

Uses

This conservation vent is ideal to cover small holes under 75mm in diameter to allow the free movement of air whilst deflecting rainwater and also reducing back draughts caused by strong winds. It could be used for weep holes or small diameter core drilling for low KW combustion appliances etc.

Below is a list of the uses for the larger conservation vents with spigots

Mainly used as an exterior vent to extract damp and moist air from inside a building. Hob extractors, kitchen extractors, cloakrooms, wc, bathrooms, ensuites and tumble dryer outlets are the main uses. As the name suggests it does suit period properties although it's quite a statement piece even on contemporary buildings but it has been used on a significant number of listed buildings and properties in conservation areas. It may need listed buildings consent to install it but, so far, we haven't heard of any conservation officer that has refused its introduction. The conservation vent has been instrumental in improving extractor efficiency as installers have told us they've been able to extract close to where the fan is positioned whereas in the past they've ducted metres and metres of flexi pipe to terminate on a back wall to appease the authorities.

It can also be used as an interior vent to allow air in for combustion especially with regards to stoves. It's elegant dome and undisputed Victorian charm are most at home in the kitchen providing 7200mm² of free area for combustion air to oil fired Agas or background kitchen ventilation to enhance the look even with electric ovens.

Buildings predominantly installing these grilles are large buildings for restoration and conversion to apartments, care homes, manor houses and also farm houses.

The larger 6" CON6 is ideally suited for larger properties and industrial conversions and commercial outlets where a larger air flow is required. We have three installed at our own farm house (17th century) on the tumble dryer outlet, kitchen extractor and at the end of drain water outlet. Here are a few examples of notable buildings:- Glasgow University, Godinton House Kent, Causeway Weymouth, Castle Gayer Cornwall and Roger Needham Building Cambridge University.

Finish

We supply them either primed red oxide for clients and contractors to paint on site or painted black. We can supply bespoke RAL painted to match customers' existing brickwork or requirements. Please note that items painted in such a way are nonreturnable, there is an additional charge for this and it will add 1-2 weeks onto the delivery time. Let us know if you want it supplied bare metal so it will form a rust finish (it will still last a lifetime even if it is rusty)

Environmental Benefits and Longevity

All the cast iron air bricks we commission are UK made and this product is made in Nottinghamshire, England. The larger conservation vents with spigots are made in Oxfordshire and West Bromwich, England.

Cast iron is not affected by UV and is fire resistant and fully recyclable. The cast iron used in the manufacture of this product is sourced from scrap iron with the addition of a small amount of pig iron. On average, 95% of the casting is recycled material. The moulds used to create the castings are generated using sand that is packed in a box with one of our patterns and this sand is used again and again to create further castings.

Casting in the UK has ensured all our products are made to strict emission and pollution levels in accordance with the latest legislation and that the workers creating these products are fairly paid and have a safe working environment in which to earn a living.

Melting iron requires a substantial amount of energy from either gas or electricity and to offset the CO2 emissions from this process we have planted over 300 trees in our own 3 acre wood. The annual absorption of CO2 from our wood is enough to ensure the production of our castings is carbon neutral.

As we don't import any of our products, the mileage from foundry to our finishing workshop and distribution bay in North Devon is very low keeping our carbon footprint small and once installed we expect this air brick to last a life time.

Maintenance

Bare cast iron will rust but this rust forms a protective layer to prevent further corrosion and requires no further maintenance, it is ideal for installation in red brick properties but may stain light coloured brickwork or light coloured rendered properties.

Painted vents use two part epoxy black gloss top coat which is hard wearing but is just a decorative finish, like all painted cast iron products it will require repainting from time to time, especially if situated on an exposed wall. Repainting can be frequent if the grille is positioned in the sunlight, or chipped or exposed to salt air . The gloss paint will dull over time, in exposed conditions it is likely to dull to a satin sheen fairly quickly. Regardless of the paint finish the cast iron grille will last for many decades with or without painting.



Notes for architects

Stunning, cast iron, authentic, vent for period properties requiring sympathetic, extractor outlets with the benefit of back draught prevention from a cowled front.

These grilles should be used along with the appropriate 4, 5 and 6 inch diameter core drilled holes when attaching to exterior walls.

The 3" CON3 is actually 73mm and because it doesn't have a spigot at the back, it can cover any size hole from 73mm or smaller, even a square or rectangular one.

The larger conservation vents (4, 5 and 6") can be used in conjunction with a number of additions such as mesh, flaps and ducting which we have available. The 3" version only has mesh that can be used with it as we do not sell any flaps or ducting or pipework for it. It might be possible for you to procure tubing, elbows, flexi duct in small diameters depending on the core drills you are using but we don't stock these.

We can supply a square of loose mesh if desired so it can be trapped at the back of the grille when it is screwed to the wall. The mesh is removable for cleaning by unscrewing the grille and should be inspected regularly and cleaned either by blowing air or vacuuming if the debris is non-greasy or can be dissolved in a degreaser such as acetone and drying before reinstallation.

We do not supply screws but, as the unit is nearly a KG we suggest installers use screws with sufficient length to ensure the grille is firmly secured to the wall. This is especially important if it is installed above head height. As with all installation of mesh used in ventilation grilles, specifiers should be aware of the latest Gas Safe and HETAS regulations regarding solid fuel, oil and gas appliances.



SPECIFICATION TABLE – COWLED CONSERVATION VENT

Item Code	Nom. Size (Inch) Spigot dia	Size in mm Spigot dia	Vent Size (mm)	Weight (KG)	Free Area (mm ²)	Free Area with mesh (mm)	Plate thickness (mm)
CON3	3 (no spigot)	73	-	0.9	4000	2640	6
CON4	4	100	-	2.5	7200	4750	8
CON5	5	125	-	2.5	7200	4750	8
CON6	6	148	-	5	11,100	7325	8

(Full dimensional table is at the end of this document) **Material – Grey cast iron 250**

British Made Product

Cast iron foundry source – Oxford, Nottinghamshire and West Bromwich England

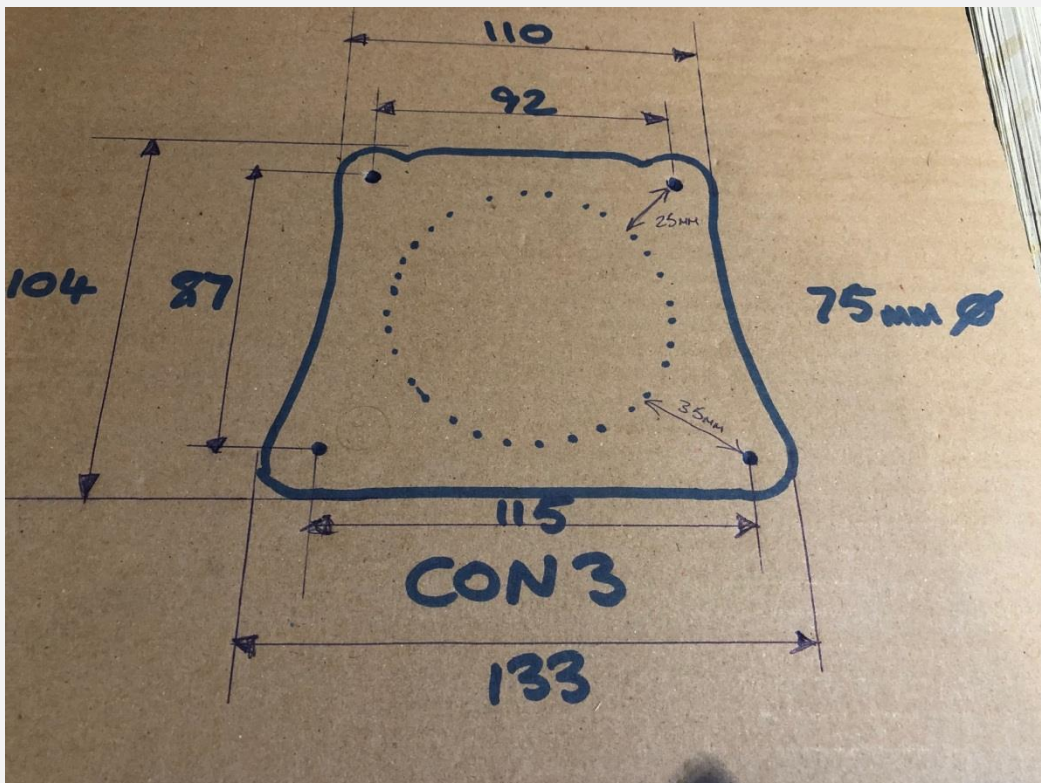

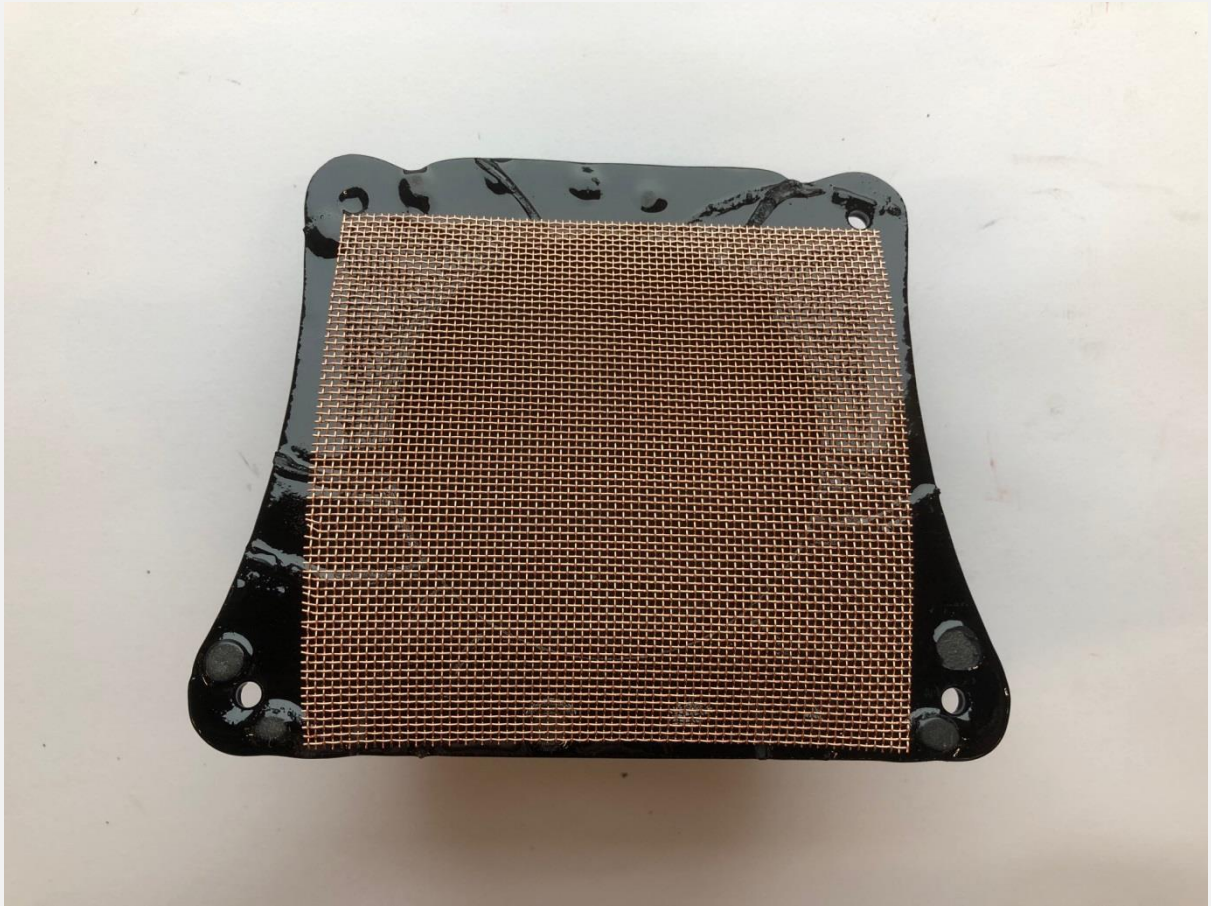

For more details please see our website...

<https://www.castironairbricks.co.uk/product-category/period-vent-grilles/>

Alternatively email or call us

Sales@castironairbricks.co.uk

01598 711999

Delivery for this product is normally from stock for low volume orders and these are sent out the next working day for orders received before 12 o'clock. Ideally we hold 50 units bare metal and 5 units primed red oxide and painted black of each size although this is a guide and can quickly change. If we need to prime more red this will add a couple of days to delivery, paint more black this will be 5- 7 days longer and bespoke painted fronts (customer supplied RAL) are typically 10-14 days

Cast Iron Air Brick Company, Down Farm, Brayford, EX32 7QQ

Conservation Vent Dimensions in mm

	CON3	CON4	CON5	CON6
Max Width (at Base)	133	183	183	235
Vent Height	104	135	135	165
Width at Top	110	155	155	195
Hole distance between centres	115	160	160	208
Hole distance between centres	87	117	117	165
Hole distance between centres	92	130	130	173
Vent Protrusion	60	78	78	92
Spigot Length		24	24	35
Drilled Securing Hole Diameters	5	5	5	6
External Spigot Dia	na	104	124	148
Internal Spigot Dia	na	92	110	134
Weight KG	0.9	2.5	2.5	5.0
Free Area mm ²	4000	7200	7200	11,100



CAST IRON AIR BRICK COMPANY

Building Architectural Enhancements

riba
product
selector

Specification Sheet – ciabCON3-2021

www.castironairbricks.co.uk